

刻印ブロックパンチ 刻印方形凸模

精密級刻印ブロックパンチ 精密級刻印方形凸模

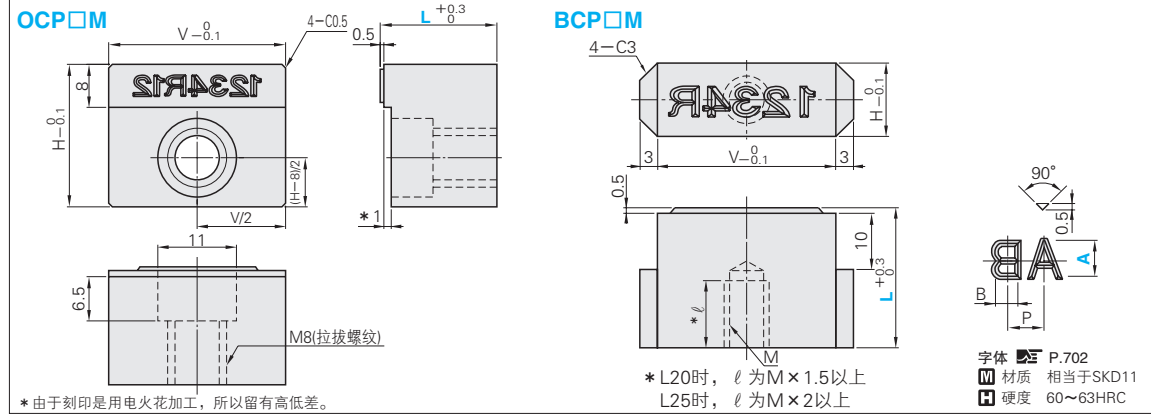
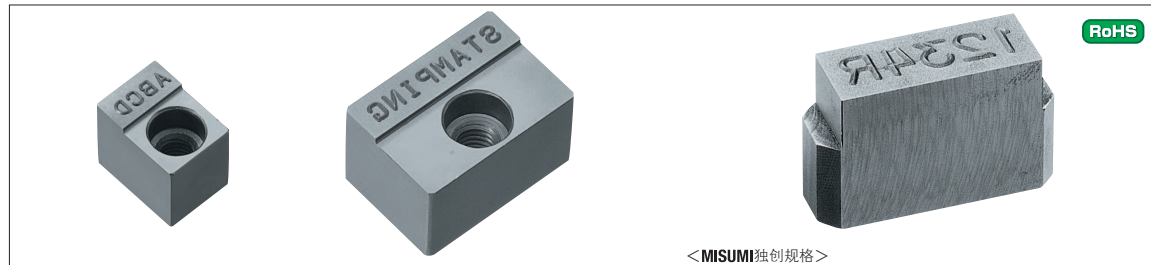

安装螺栓 M	V	H	P	B	Catalog No.		A	L	文字(粗体) CHR
					Type	文字数			
6	16	22	3.5	2	OCP	3M	3	20	0 1 2 3 4 5 6 7 8 9 A B C D E F G H I J K L M N O P Q R S T U V W X Y Z
						4M			
						5M			
						6M			
6	25	10	3.5	2	BCP	3M	3	20	(注1) [] (空格) (注2) - (连字号)
						4M			
						5M			
						6M			
8	25	13	6.0	4	VCF	3M	6	25	
						4M			
						5M			
						6M			

①(注1)请用%指定 [] (空格)。②(注2)请用#指定 - (连字号)。

Order 订货范例 Catalog No. - A - L - CHR 刻印的配置范例
 OCP3M - 3 - 20 - ABC
 OCP3M - 3 - 25 - %AB
 OCP4M - 3 - 20 - ABCD
 OCP4M - 3 - 25 - A#B%

Delivery 交货期 5 天发货
 ① 上海·广州发货
 ② 数量≥101时，请另询交货期。

Price 价格 询价联系方式：
 WOS: <https://www.misumi-ec.com/cn/> P.57
 TEL: 021-6710-8701 / FAX: 021-6710-8984 P.1663

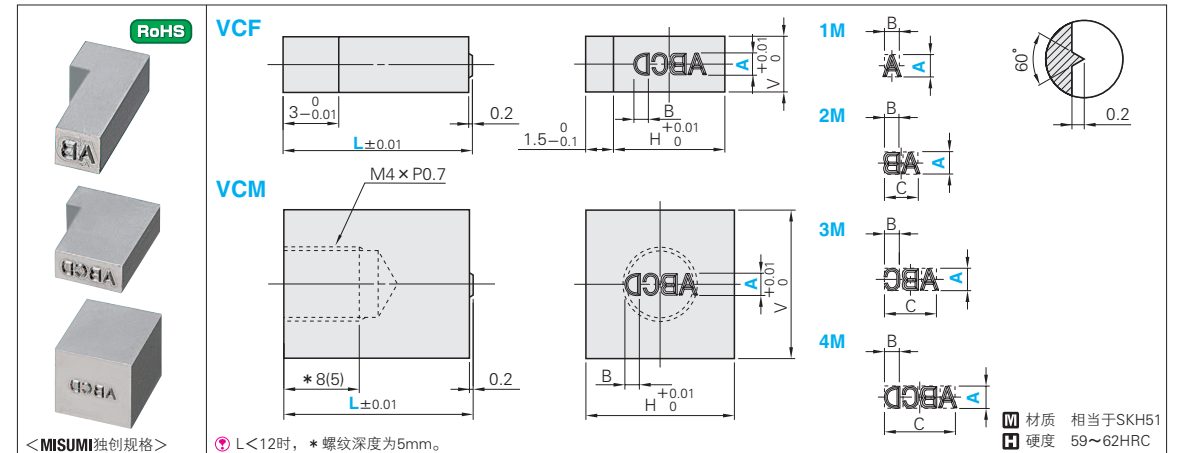
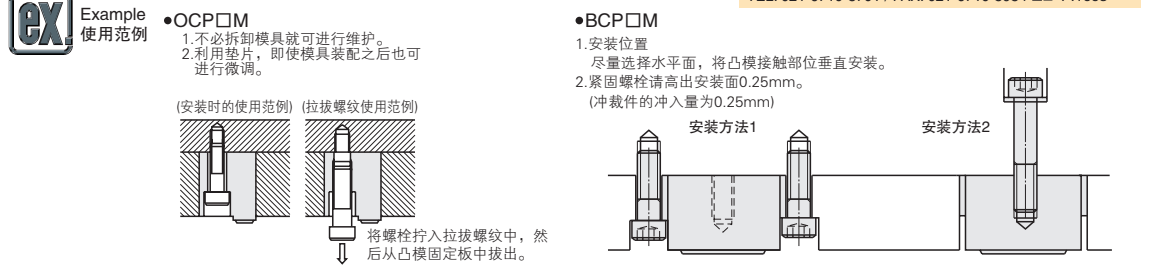

V	H	A	B	C	Catalog No.		指定单位0.1mm L	文字(粗体) CHR
					Type	文字数		
3	2	1.0	0.7	-	VCF	1M	8.0~30.0	0 1 2 3 4 5 6 7 8 9 A B C D E F G H I J K L M N O P Q R S T U V W X Y Z (注1) [] (空格) (注2) - (连字号)
		1.2	0.8	-				
		1.5	1.0	-				
		1.0	0.7	1.8				
		1.2	0.8	2.0				
		1.5	1.0	2.4				
	3	3	1.0	0.7		3.0		
			1.2	0.8		3.3		
			1.5	1.0		3.9		
			1.0	0.7		4.1		
			1.2	0.8		4.5		
			1.5	1.0		5.3		
8	8	1.0	0.7	-	VCM	1M	8.0~30.0	(注1) [] (空格) (注2) - (连字号)
		1.2	0.8	-				
		1.5	1.0	-				
		1.0	0.7	1.8				
		1.2	0.8	2.0				
		1.5	1.0	2.4				
	8	8	1.0	0.7		3.0		
			1.2	0.8		3.3		
			1.5	1.0		3.9		
			1.0	0.7		4.1		
			1.2	0.8		4.5		
			1.5	1.0		5.3		

Order 订货范例 Catalog No. - A - L - CHR 实际的刻印
 VCF3M - 1.5 - 20.0 - ABC
 VCF3M - 1.5 - 25.0 - %AB
 VCM4M - 1.5 - 20.0 - ABCD
 VCM4M - 1.5 - 25.0 - A#B%

Delivery 交货期 13 天发货
 ① 上海·广州发货
 ② 数量≥101时，请另询交货期。

Price 价格 询价联系方式：
 WOS: <https://www.misumi-ec.com/cn/> P.57
 TEL: 021-6710-8701 / FAX: 021-6710-8984 P.1663

Alterations 追加加工 Catalog No. - A - L - CHR - (VHM·VHZ...etc.)
 VCM3M - 1.2 - 15.0 - ABC - CCP180

Alterations	Code	Spec.
	VHM	变更杆径 尺寸公差 V+H +0.01 ⇨ -0.01
	VHZ	变更杆径 尺寸公差 V+H +0.01 ⇨ ±0.005
	HC	变更凸缘宽度 0≤HC<1.5 指定单位0.1mm VCM不适用
	CCP	杆部1处C倒角(错误防止用) 杆角1处进行C1.0倒角处理。 指定C倒角位置(从刻印面侧看时) CCP0 CCP90 CCP180 CCP270 VCF不适用

精密级刻印方形凸模精度标准

精度标准		
垂直度		a ≤ 0.005
平行度		b ≤ 0.005