

磁性座/支柱固定夹



CAD数据文件夹名: 29_Posts

■特长: 由于使用了钕磁铁,既小型又具有强大的吸力。悬臂的配套件请参阅P.1708

Order 型式(Type · No.)
订货范例 MGNBS80

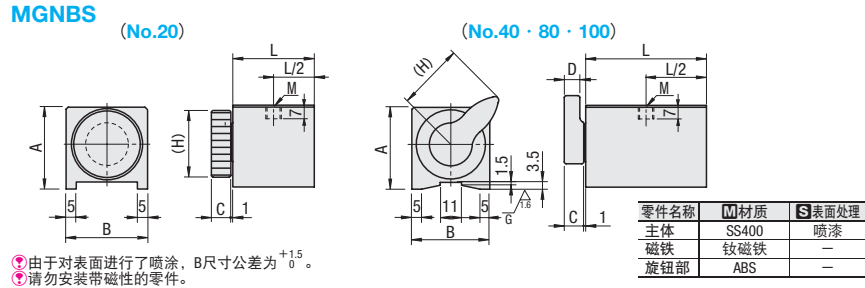

型式 Type	No.	吸附力 N	A	B	L	(H)	C	D	M (粗牙螺纹)	自重 (g)
MGNBS	20	200	30	30	30	25	9	-	M6	200
	40	400	40	40	42	-	-	-	M6	400
	80	800	42	40	62	34	10	8	M8	700
	100	1000	42	40	73	-	-	-	M8	800

Delivery 交货期: 隔日上海·广州发货 (17:00前订购的库存品可当日发货。)

库存品: 隔日上海·广州发货 (17:00前订购的库存品可当日发货。)

数量分类: 标准订购 小单 1~20, 特殊订购 大单 21~

请按照选型步骤 1~3 选择型式和参数后进行订购。

Order 型式(1Type · 2D) - 3D1
订货范例 KSHL10 MGNBSH10 - 8

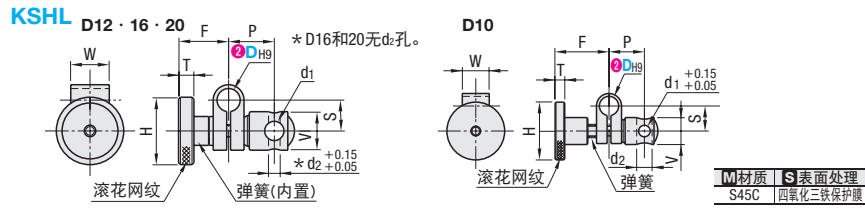

型式 1Type	2DH9	直径 d1	公差	d2	P	F	H	S	V	T	W	自重 (g)
KSHL	10	8	+0.036	6	18.4	28	30	13	14	5	14	70
	12	10	+0.043	6	24	26	35	16	20	8	20	140
	16	12	+0.052	-	27.5	32	40	22	22	8	28	225
	20	16	+0.052	-	38.5	40	50	28	28	10	30	475

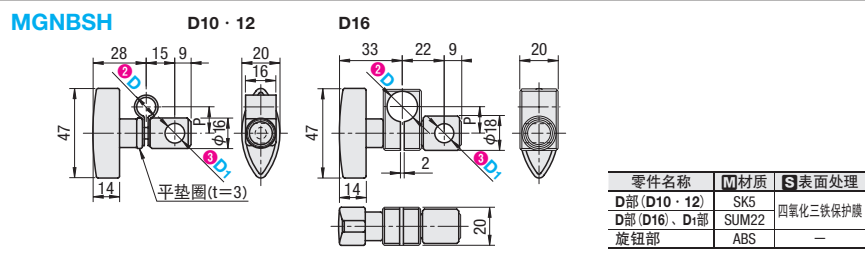

型式 1Type	2D	3D1	P	自重 (g)
MGNBSH	10	8	14	50
	12	10	16.5	50
	16	12	14	100
	20	16	14	100

Delivery 交货期: 隔日上海·广州发货 (17:00前订购的库存品可当日发货。)

库存品: 隔日上海·广州发货 (17:00前订购的库存品可当日发货。)

数量分类: 标准订购 小单 1~20, 特殊订购 大单 21~

刻度盘安装用夹具/指示器安装用夹具/刻度表用夹套



CAD数据文件夹名: 29_Posts

Order 型式
订货范例 MGNBSD DGHL1

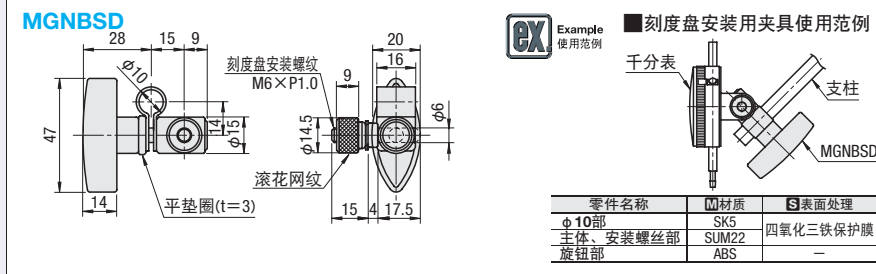

型式	自重 (g)
MGNBSD	70

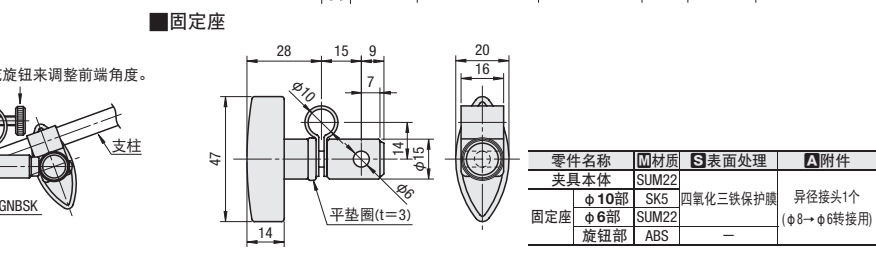
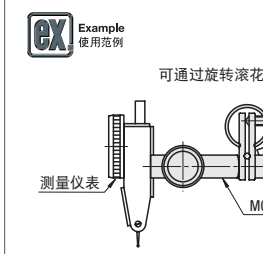
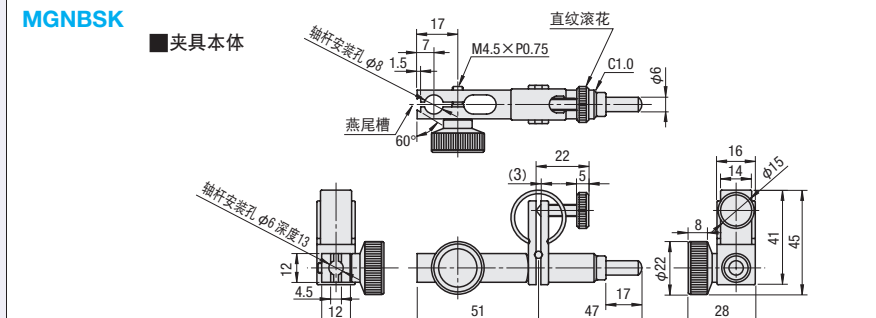

型式	自重 (g)
MGNBSK	170

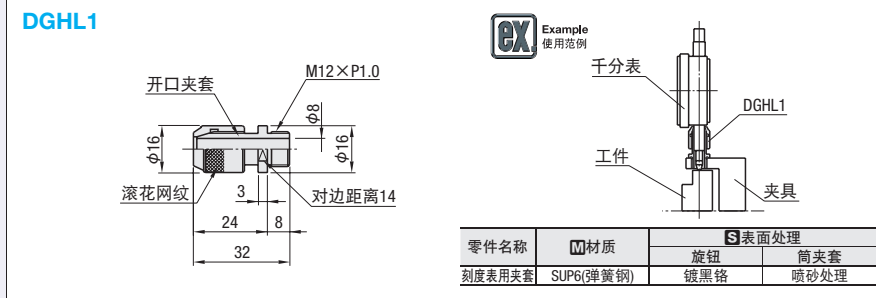

型式	自重 (g)
DGHL1	20

Delivery 交货期: 隔日上海·广州发货 (17:00前订购的库存品可当日发货。)

库存品: 隔日上海·广州发货 (17:00前订购的库存品可当日发货。)

数量分类: 标准订购 小单 1~20, 特殊订购 大单 21~